

Range of application

This standard applies to flanged slide valves which are used on ships in the Federal German Navy, preferentially in piping for fresh water and seawater at working temperatures up to 100°C.

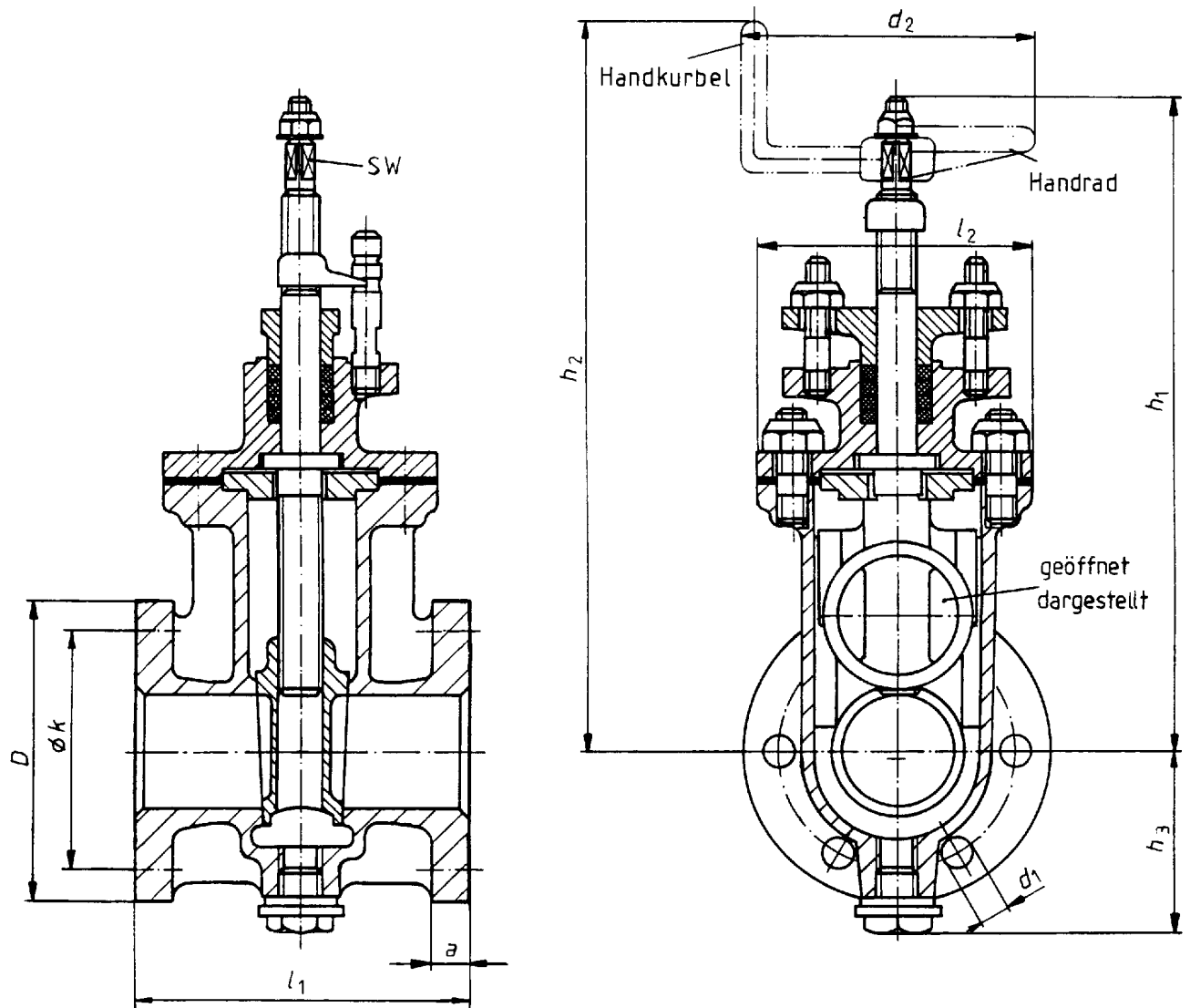

Designation of a flanged slide valve with stuffing-box packing (P) of nominal size 40 :

Flanged slide valve VG 85060 - P - 40

Nom. size DN	l_1 ± 1	l_2 max	h_1 max	h_2 max	h_3 max	Dimensions for pipe connection flange					AF	Handwheel / -crank ¹⁾ d_2	
						D	a	k	Screw holes				
									Qty.	d_1 for screws			
40	120	98	227	260	79	108	10	84	6	11	M10	9	100
50	120	98	245	278	84	120	10	96	6			9	100
70	140	152	297	340	98	140	12	116	8			11	125
80	140	154	314	357	103	150	12	126	8			11	125

¹⁾ Handwheel or crank (see VG 85081) are not included and must be ordered separately.

Range of application

This standard applies to flanged slide valves which are used on ships in the Federal German Navy, preferentially in piping for fresh water and seawater at working temperatures up to 100°C.

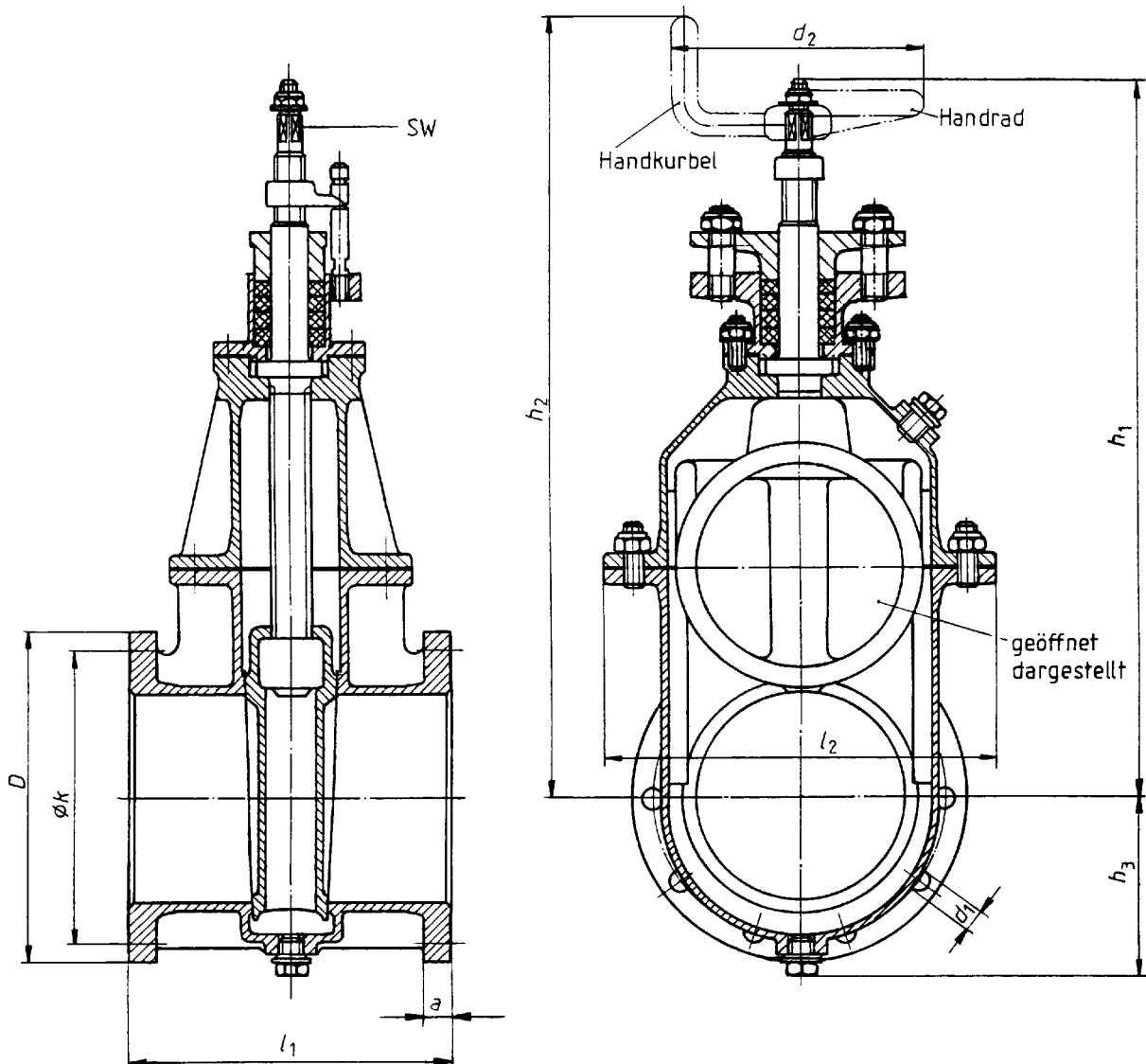

Designation of a flanged slide valve with stuffing-box packing (P) of nominal size 125 :

Flanged slide valve VG 85060 - P - 125

Nom. size DN	l_1 ± 1	l_2 max	h_1 max	h_2 max	h_3 max	Dimensions for pipe connection flange					SW	Handwheel / -crank ¹⁾ d_2	
						D	a	k	Screw holes				
									Qty.	d_1			for screws
100	180	206	395	440	117	172	12	148	10	11	M10	14	175
125	190	234	426	470	131	200	14	176	10			14	175
150	190	262	477	525	146	226	14	202	12			17	200

¹⁾ Handwheel or crank (see VG 85081) are not included and must be ordered separately.